



The John Tebbutt Space Telescope

The Search for Exo-Life

Description, Rules and Procedures v0.2 20180321

Task Description

The Australian Space Technology Research Organisation (ASTRO) is developing the John Tebbutt Solar Lyapunov Orbit Optical exo-Planet Survey¹ (SLOOPS) Space Telescope as the next generation of deep space observatory – seeking to image extra-solar planets previously unresolvable by optical telescope. It aims to have sufficient resolution that biospheres of habitable exo-planets may be discerned. The project objective is to build an optical space telescope system capable of orienting itself in space, directing and stabilising its optical stage towards targets in space, imaging distant planets and transmitting the data back to the operators.

Stellar targets will be represented by “eye chart” placards. The telescope’s ability to resolve fine visual details (ie. smaller fonts on the placards) will provide additional information about the star system being observed. Targets will be placed at positions in space given as equatorial geocentric spherical coordinates centred on the telescope’s location at the Earth-Sun L1 Lagrange point. Upon activation, the telescope must wait to receive instructions from the ground controllers and, when commanded to do so, target each placard and take an image. The image is then to be sent to the ground control station, recorded to disk and presented to observers on the ground via a live video feed.

The communications system for interacting with the space telescope must connect through the Deep Space Network for relaying to other sites around the world. As such, all command and telemetry signals enroute to the ground-station’s transmitter stage must pass through the DSN’s standard interface: a 1200 baud 3.3V TTL UART serial port. The very distant location of the telescope at L1 means that there will be a long delay in transmissions – this will be represented by a 10 second delay into commands passing through the DSN block. Received radio signals may be received directly, and do not need to pass through the DSN.

As the telescope is to be based in deep space², there will be no local gravity field with which to orient the telescope. The weightless space environment will be represented by mounting the telescope on a low-friction 3-axis gimbal. The telescope is prohibited from pointing directly along the Earth-Sun axis, due to risk of damaging the fragile optics from the bright sun and Earth. Thus, the 3-axis gimbal’s singularities (“gimbal lock” positions) will be aligned in this axis.

The spacecraft will be launched from Woomera Launch Aera 5 on an ASTRO Wedgetail X rocket, which has strict payload dimension and mass limitations. The fixture geometry for the gimbal will be the same as per the payload adaptor of the launch vehicle.

¹ Co-funded by ASIO, along with its sister-craft the Synchronous Near-Earth Orbit Optical Planetary Surveillance (SNOOPS) Telescope.

² Defined as space beyond the Earth-Moon system.

All-up system testing will occur during scheduled demonstration sessions in week 13. There will also be incremental demos in weeks 7, 9 and 11, allowing partial functionality to be demonstrated. Be aware that this project specification **will** be updated through the course of the semester, with at least one guaranteed project specification change, requiring your design to be flexible to accommodate changes.

Testing Procedure

During testing, the telescope will be commanded to point at different stellar objects provided as a series of polar coordinates given in degrees of Declination and Right Ascension. The gimbal testing area is at a fixed position on a 4th level catwalk overlooking the Hawken main gallery (marked in tape with an "x"). Zero degrees Declination corresponds to a horizontal plane parallel to the Hawken building's floor, at the level of the gimbal's centre. Zero degrees Right Ascension aligns with a vertical plane parallel with the length of the Hawken gallery, towards the West (also marked on the floor of the catwalk in tape). Four calibration targets will be provided at *a priori* known stellar coordinates, which will not move during the course of the project.

During testing demonstrations, four additional sets of target coordinates will be provided. Points will be awarded for providing images of the planets and sufficiently resolving the text such that correct information about the planet may be reported. No automatic text recognition is required, but points will only be awarded for 100% correctly reported strings of text from the target placards.

As bonus functionality, if all of the information can be correctly read from the testing placards, the telescope may commence the exoplanet observation mission by searching across a large peg board of placards using a given list of target coordinates. A subset of the placards will have notable planetary information (marked on the cards as "(NOTABLE)") which may be reported for bonus points. One of the placards will indicate "LIFE", which provides a higher bonus. To gain the bonus points, both the notable information and the corresponding stellar coordinate must be provided.

Each demonstration session will run for 25 minutes, during which students must complete all required setup, install the telescope on the gimbal, carry out the optical search across given target locations and present resultant findings to the adjudicator. The telescope will be set to start at an arbitrary, random orientation. The command station will be set up on the 2nd level of the Hawken gallery, remote from the gimbal on the 4th level. After 25 minutes, the students must cease operations and will have 5 minutes to pack down and clear the gimbal and testing area, ready for the next team. The time-limits will be rigorously enforced. Build quality may be assessed at any time during the testing slot.

IMPORTANT NOTE: Due to the risk of falling parts and objects while working on the catwalk, the telescope must be installed on the testing gimbal off of the catwalk, and then the whole telescope/gimbal/tripod assembly moved into position for testing. Similarly, the assembly must be removed from the catwalk prior to deinstallation. Ready areas will be marked in tape on the ground, as will be the tripod position.

Scoring

Task performance will be assessed by a points system based on demonstrated performance and build quality. Refer to the separate build quality rubric and guidelines for build quality specifications. Only the performance of the overall system will be considered; no part will be considered separately.

Build Quality	10/10 Points
Basic Functionality	50/50 Points
Satisfy the payload flight specification	5
Demonstrate subsystem module power cycle	10
Return an image to the ground	10
Maintain a constant orientation in space	10
Return an image of a target planet	15
Advanced Functionality	40/40 Points
Target planet image returned	1 per target
Target large text deciphered (Arial 80 pt font)	2 per target
Target medium text deciphered (Arial 70 pt font)	3 per target
Target small text deciphered (Arial 60 pt font)	4 per target
Bonus Functionality	10/10 Points
Search board survey planet small text deciphered	1 point each
Life detected	5 points

Apparatus

The apparatus consists of the mission payload optics, stellar target placards, peg board, DSN delay block and 3-axis gimbal system sized to the maximum dimensions of the spacecraft.

The mission payload is the Super Diaphanous Kenko 15x32D optical stage with filter, provided without an imaging system. The objective lens diameter is 32mm, and the combined optics have a magnification of 15x. The optical stage is an irregular shape approximately 103 mm long (see Fig. 1). The output of the optical stage is offset from the objective lens axis through a reflector stage; a threaded connector with 15.25 mm diameter is provided for affixing a camera stage.

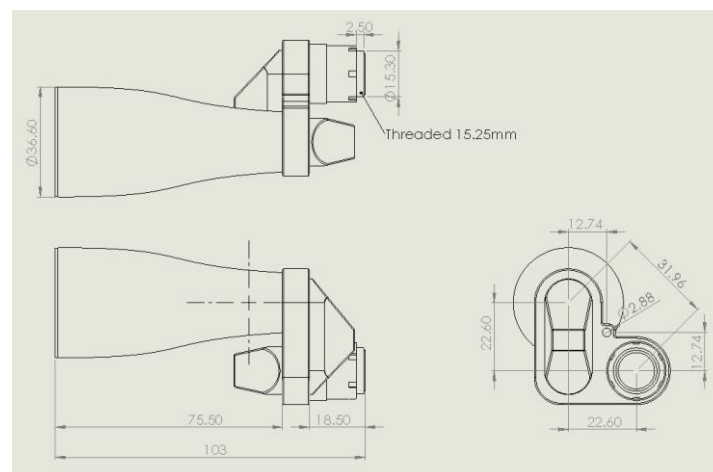

Figure 1: Provided optics stage

The stellar target placards consist of A4 sheets of cardstock with a hanging hole at one end. On the surface of the card are printed a image of the exo-planet target, along with the data text to be read from transmitted photographs (see Fig. 2). The size of the planet image will be variable across cards, but typically ranging from 50 mm in diameter to 125 mm diameter.

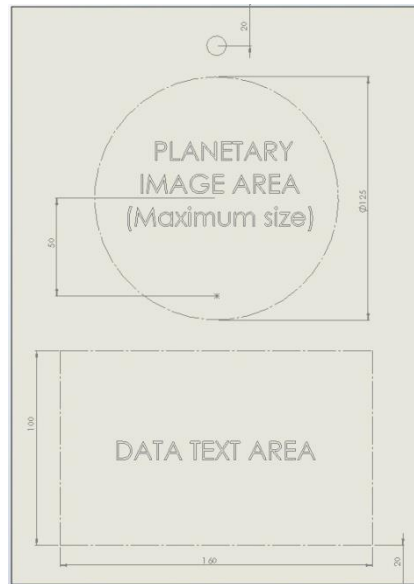

Figure 2: Placard Geometry

The placards will either be permanently fixed for standard testing, or mounted on a pegboard for the bonus search task. The pegboard will consist of a series of hooks on which the placards will be hung; the planetary image will be 78.5 mm below the hanging point. Stellar coordinates will be given with reference to the centre of the planet image. The pegboard will be no more than 4x2 m in size.

The DSN delay block interface is a three-pin 2.5mm header at either end – one of which has a UART input, and the other has a UART output. Signals from the command and control system are received by the RX pin and then replayed after the specified delay on the TX pin.

DSN Input Pinout

Pin	Assignment
1	GND
2	3.3 V
3	RX

DSN Output Pinout

Pin	Assignment
1	GND
2	3.3 V
3	TX

System Design Guidelines

Each team must construct an optical telescope observatory space vehicle system and attendant support equipment using a limited budget. The adjudicator shall be the final arbiter of whether any part of the system, or the system as a whole, is legal within the guidelines. Students may provide their own laptops or desktop computers, which do not count towards size or budget limits.

Modularity and stand-alone testing

The key components of the spacecraft system must be modular, such that each major subsystem can be removed and validated separately:

1. Mechanical and power management bus
2. Orientation control system
3. Telemetry and imaging
4. Ground control interface.

Each part must be capable of being demonstrated to a basic level with any or all of the other systems missing or non-functional (with the exception of the mechanical bus). During individual validation, other components may be represented by a “boiler plate” – eg. a bench power supply for bus power, wired serial input for communications and weighted ballasts to represent component masses for orientation control testing. The mechanical and electrical interfaces between each subsystem must be fully specified and documented for submission. Telemetry, orientation control and imaging systems must each possess a LED that indicates the powered/unpowered status of that subsystem.

Construction

Dimensions

The telescope spacecraft’s dimensions and mass are limited by the payload space available within the launch vehicle’s aerodynamic shroud (see Fig. 3). Furthermore, the total allowable mass of the assembled spacecraft and any payload adaptor/fasteners is limited to 750 g. These limitations are extremely strict: they will be tested on the day, and non-compliant spacecraft will not be assessed. Furthermore, the flight stability of the launch vehicle requires that the Centre of Gravity (COG) of the payload be 90 mm ahead of and aligned with the centre axis of the payload adaptor firewall (see Fig. 4). Failure to correctly tune the COG will compromise the performance of the flight vehicle (and also cause the telescope to slump in the gimbal).

The entire system, including all support equipment (except laptop/desktop computers), must fit inside a ~~typical shoebox~~ BX3 Australia Post mailing box³ for final submission. The system may be partly deconstructed to fit in the shoebox, with the understanding that students must reconstruct it during the strictly time-limited testing slot for the final demo. Students are strongly advised to design their system with the boxing requirement in mind.

³ This was changed due to abuse of the definition of what constitutes “shoebox” by previous students. Suffice it to say, if you have to redefine commonly understood terms of reference to make your design meet the specification, your work is probably not going to pass muster.

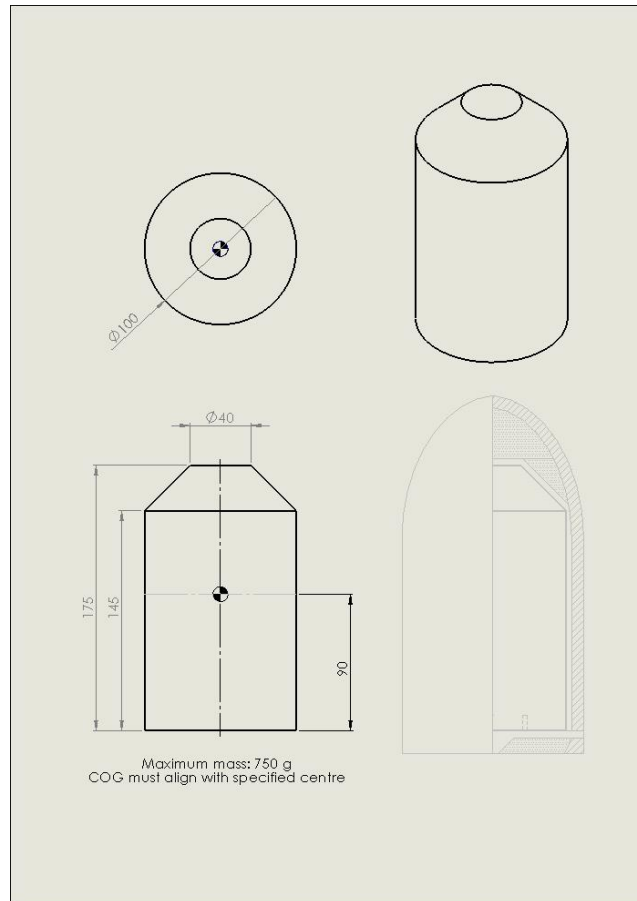

Figure 3: Permissible payload convex hull and COG location

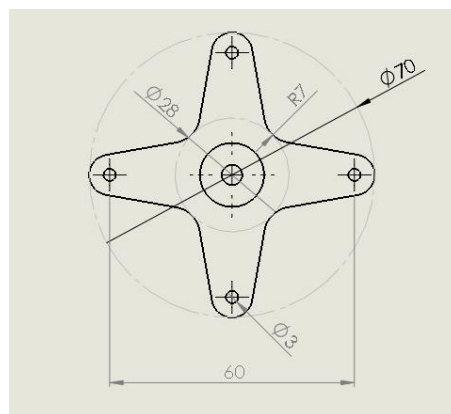

Figure 4: Payload adaptor firewall mounting geometry

Materials and Fabrication

CASA and ASTRO have not certified 3D printed structures for spaceflight. No part of the submitted spacecraft hardware may be 3D printed, except by special exemption of the adjudicator. Ground-based system components may include 3D printed structures (eg. brackets, supports, enclosures). At least one custom PCB must be produced.

Control

The telescope system does not need to be autonomous; teleoperation from a control station is allowed. No wired links between the spacecraft and the control station shall be permitted. There shall be no physical contact between the operators and the spacecraft except to set the system in place at the testing position, or remove it. Computer mice and keyboards are considered part of the computer system provision and do not count towards the budget; handheld control interface components such as joysticks, gamepads or space mice are not considered part of the computer, and must be accounted for.

The team must provide a visual datafeed (VGA or HDMI) from the telescope imaging sensor for display. The datafeed will be displayed on a provided large screen monitor on testing day for use by the adjudicator and observers.

The telescope will be operating in deep space without air or gravitational references. No part of any onboard system may require the presence of gravity or an atmosphere to operate. This includes inclinometers, accelerometers and any sensor with integrated inclination compensation (as found in many compasses). Gyroscopes are ok, as long as they do not include any accelerometry. It is not sufficient to claim accelerometers are “turned off” or not being used. The sole exception (at the adjudicator’s discretion) is where an accelerometer is being used solely for the purpose of measuring acceleration due to motion. Likewise, rotors, propellers or actuated pendulums for orientation control are prohibited (passive weights to fine-tune balance the payload COG are ok).

Power Sources

Stored energy in the spacecraft is limited to charged electrical devices and stored elastic energy; no stored gravitational, kinetic, nuclear or thermal energy systems may be used. Exceptions may be granted by the course coordinator on a case-by-case basis. For safety reasons, any proposed elastic energy storage device must be approved by the adjudicator. **Li-poly batteries may total no more than 15 kJ maximum energy capacity.**

Processors and programming

Pre-fabricated processor and computer modules may be used. However, due to abuse by previous students, no Atmega 324/328 processors may be used, and Arduino software (IDE, scripts etc) is strictly prohibited. Exceptions may be granted by the course coordinator on a case-by-case basis (for example, a commercial product that incorporates a 328P processor, but which is non-reprogrammable). It is strongly recommended that teams program using C.

The spacecraft flight control system will be exposed to a deep space environment. As such, the mission-critical systems must be controlled by a “management microcontroller” that is available in a space-rated version. The management microcontroller must be able to power cycle the orientation control, telemetry and imaging subsystems on command from the ground station. The specific part used and budgeted does not, itself, have to be an actual space-rated device – but that model of microcontroller must come in a space-rated version with identical performance specs. Other controllers used within the various subsystems do not need to be radiation hardened.

Budget

The total cost of materials, parts and components incorporated in the product shall be no more than \$200 (excluding laptop/desktop computers). Regardless of actual cost to construct, the team must demonstrate that the product produced *could* be constructed from parts costing less than or equal to \$200. Up to \$200 will be provided for purchase orders through ETSG.

Reimbursements will *not* be permitted.

Cost of parts shall be calculated on a per-item basis; parts that are purchased in multiple units may be costed per unit – e.g. a bag of 10 nails for \$10 may be charged at \$1 per nail used. Bulk unit discounts from suppliers may be applied, provided the quantity of items used in the product is sufficient to earn the discount. Items sourced for free (i.e. not paid for) may be costed at half the market purchase price. Circuit boards must be purchased via ETSG in order to be paid out of budget.

Each team will be provided with 500 g of 3D printer filament in a specified colour. Once this material has been exhausted, no further filament will be provided or nor may be purchased with the build budget. Only the provided filament may be used in submitted work, where permitted. The cost of provided filament does not count towards the budget total.

Specific Prohibitions

- **No off-board imaging of placards**
Cameras for imaging the placards may only be mounted on the spacecraft part of the system. This is a space telescope, not a ground telescope, afterall!
- **No outside markers, attachments or alterations**
No signs, structures, markers, radio beacons may be installed in addition to those provided. No alterations may be made to the Hawken building or other apparatus. You may not touch the gimbal in anyway aside from the provided mounting plate. Systems that cause damage to the apparatus will be prohibited from operating.
- **No internet connection**
No part of the spacecraft system, support equipment or off-board processing facility may be connected to the Internet. Where WiFi or similar wireless protocols are used to connect between spacecraft system and another computer, it must be demonstrated that no computer on its network is connected to the Internet. The instructor may elect to have the connection status of any input device demonstrated prior to testing. The instructor shall be the final arbiter of whether a connection constitutes connection to the Internet.

The Aim of the Project and the Spirit of the Rules

Without a doubt, engineering students are extremely creative and talented at finding clever solutions to difficult problems. This project aims to teach you about the practical trade-offs encountered by engineers when facing a multi-faceted challenge with broad scope and many possible solutions. It is recognised that no set of rules could cover every possible edge-case without becoming cumbersome fodder for 'rules lawyers'.

Thus, the two cardinal rules are:

1. The instructor's decision is final.
2. Stay within the spirit of the problem.

If you think what you are attempting might not be in accordance with the spirit of the rules, there is no harm in asking! The instructor will rule whether a particular approach is permissible. Obviously, it is best to ask these sorts of questions early in the semester and before committing to a particular solution!

Other Miscellanea

By-laws, clarifications and addenda go here. This used to be a short section, but previous years' students have shown that it is *depressingly* necessary to spell-out exactly what you should not be doing. But you're going to be smarter and better dressed than them, *right?* ☺

1. All OH&S inductions and procedures *must* be adhered to. You **WILL** be ejected from the lab if you are unsafe or in violation of footwear requirements. Repeat offenders will be barred from the teaching labs for the remainder of the semester.
2. It is the responsibility of all students to keep the teaching labs in clean, functioning condition. Lab cleanliness will be arbitrated by a warning system, as posted on the class blackboard site and class website.
 - a. The lab status starts at GREEN.
 - b. If the condition of the labs deteriorates and becomes messy, status will change to YELLOW, indicating that a clean-up is needed.
 - c. If conditions do not improve or deteriorate further, the status will be changed to RED and the labs will be set to fixed-hours, with after-hours access prohibited.
 - d. If conditions still do not improve or deteriorate further, the status will be changed to BLACK and the labs will be locked to students until the next practical session, whereupon the labs must be completely cleaned before any non-cleaning work may resume.
3. The following are specifically prohibited inside the lab:
 - a. Eating or drinking in the lab (including water), or having food or drink outside of a backpack or bag.
 - b. Sleeping in the lab
 - c. Leaving the lab door open (all students have access cards)
 - d. Giving non-enrolled students/non-students access to the lab
 - e. Non-work related activities (e.g. computer games)

Students found to be violating these rules will have lab access revoked.

4. Under no circumstances may project infrastructure, test equipment, tools, supplies, furniture, etc. be removed from the teaching labs. 'Vegas rules' are in effect: what happens in c404 *stays* in c404. Transgressors will be barred from the teaching labs for the remainder of semester.
5. No grade will be awarded until all assigned tools and equipment are returned and accounted for. Students are separately and collectively responsible for their group's tools.